



DESIGN GUIDE

Low voltage general purpose dry type transformers

Single phase and three phase;
600 volts and below



- Commonly used reference tables
- Efficiency information
- Dimensional data

ABB's comprehensive family of low voltage dry type transformers (LVDTT) provide long life, quiet, and reliable operation.

Table of contents

General purpose ventilated DOE 2016

6	Overview single phase and three phase
7	Insulation systems
8	Single phase transformer data
11	Three phase transformer data
13	Sound levels
13	Electrostatic shielding
13	Nomenclature
14	Common voltages
15	Mounting and placement
15	Ventilation
15	Cable conduit entrance/lugs
16	Cleaning and maintenance
16	Applicable standards
17	Transformer main components
18	Testing
20	Accessories and lug kits
22	Enclosure parts
23	Dimensions
25	Selection
25	Glossary
26	Information annex

This page left blank intentionally.

Welcome to ABB's low voltage dry type transformer design guide. The purpose of the guide is to provide the data you need to complete a job specification or provide a quote. This document contains technical data such as NEMA ST-20 maximum audible sound levels, rated line amperes, energy efficiency data and dimensional data for our single phase and three phase general purpose transformers.



General purpose ventilated DOE 2016

Overview single phase and three phase

Introduction

Type QL are ABB's large power transformers ranging from 15 kVA to 1000 kVA. The QL transformers come in standard NEMA 2 enclosures with rain shield kits available for NEMA 3R installations. Stainless steel enclosures are available as options as well. QL transformers are available in single or three phase configurations with either aluminum or copper windings. Type QL's are DOE 2016 compliant with models available for Canadian NRCan efficiency standards.

All of the LVDTTs through 1,000 kVA are UL listed under the requirements of Standard 5085 and/or 1561. In addition, each transformer meets the requirements of NEMA ST-20-2014.

General purpose transformers are rated 600 Volts and below for supplying appliances, lighting, and power loads from electrical distribution systems. Standard distribution voltages are 600, 480, and 240 Volts; standard load voltages are 480, 277, 240, 208, and 120 Volts. The transformer is used to obtain the load voltage from the distribution voltage while providing galvanic isolation. Since no vaults are required for installation, these transformers can be located right at the load to provide the correct voltage for the application. This eliminates the need for long, costly, low voltage feeders.

Construction – Type QL

Large power transformers

QL units come standard enclosed in a NEMA 2 drip-proof painted metal enclosure with natural draft ventilation. The core-and-coil assembly is mounted on rubber isolation pads to reduce noise generated by transformer vibration. Rain shield kits are available for conversion to a NEMA 3R enclosure suitable for outdoor service. Type QL transformers are UL Listed: XQNX:E79145; XQNX7:E79145; XQNX2:E79145 or XQNX8:E79145.

Coil construction, 3 phase general purpose, all 100% production tested

Coil material	kVA range	Coil temperature	Terminal connections	Windings ¹
AL	15 to 150	150	Bolted	Continuous
	225 to 500	150	Welded	
	15 to 112.5	115	Bolted	
	150 to 500	115	Welded	
	15 to 112.5	80	Bolted	
CU	150 to 300	80	Welded	Continuous
	15 to 150	150	Bolted	
	225 to 500	150	Welded	
	15 to 150	115	Bolted	
	225 to 500	115	Welded	
CU	15 to 112.5	80	Bolted	Continuous
	150 to 300	80	Welded	

¹Rarely a coil may have a welded internal connection. All transformers are 100% tested, assuring internal resistance and losses are within established standards, UL and NEMA requirements.

NEMA enclosure ratings

Type QL transformers are standard as NEMA 2 painted steel enclosures. NEMA 3R or NEMA 3R stainless steel (316) enclosures are available up to 150 kVA. NEMA 3R includes the rain shield kit (also 316 SS).

To specify a stainless steel enclosure for an aluminum wound transformer, substitute the letter "S" in the fifth character of the ABB product number. For example, 9T10A1004 changes to 9T10S1004. For copper wound transformers substitute the letter "Z" in the fifth character of the ABB product number. For example, 9T10C1004 changes to 9T10Z1004. All QL model product numbers begin with 9T1, 9T7 and 9T8.

NEMA enclosure rating	Standard or optional	Installation location	Optional rain shield
NEMA 2 (ANSI 61 Painted)	Standard	Indoor	Not required
NEMA 2 (316 Stainless Steel) ²	Optional	Indoor	Not required
NEMA 3R (ANSI 61 painted)	Optional	Indoor or Outdoor	Required & painted
NEMA 3R (316 Stainless Steel) ²	Optional	Indoor or Outdoor	Required & 316 SS
NEMA 4X (316 Stainless Steel) ³	Optional	Indoor or Outdoor	Required & 316 SS

² Up to 150 kVA

³ Special order only, must be quoted and not available for all transformers

Transformer taps

Transformer taps compensate for high or low line (supply) voltages. FCAN (full capacity above nominal) and FCBN (full capacity below nominal) are standard on Type QL transformers rated 15 kVA through 300 kVA and with a primary voltage of 240 V or higher. These have a total of six available voltage taps – four 2.5% taps (FCBN) below the nominal tap and two 2.5% taps above (FCAN) the nominal tap. This arrangement provides a 15% range of tap voltage adjustment. Transformers rated 500 kVA and higher have four available voltage taps – two 2.5% taps above (FCAN) the nominal tap and two 2.5% taps below (FCBN) the nominal tap.

Insulation systems

Insulation systems

Industry standards classify insulation systems in accordance with the rating system shown below:

Transformer insulation systems

Insulation Rating	Insulation Letter Class (NEMA/UL)	Ambient	+ Avg Coil Temp Rise	+ Hot Spot Temp Rise	= Max. Coil Temp
Class 105	A	40 °C	45 °C	20 °C	105 °C
Class 155	F	40 °C	95 °C	20 °C	155 °C
Class 180	H	40 °C	115 °C	25 °C	180 °C
Class 220	R	40 °C	150 °C	30 °C	220 °C

All ABB Type QL (80 °C, 115 °C and 150 °C) DOE and NRCan compliant transformers use 220 °C insulation systems and meet all applicable NEMA, ANSI, UL, and IEEE dry type transformer standards.

The design life of transformers having different insulation systems is the same, since the allowable temperature rise of an insulation material system is predicated on a specified life for all insulation. The lower temperature systems are designed for the same life as higher temperature systems.

Key to the chart

- All assume 40 °C ambient temperature.
- Coil temperature rating (Temp Rise) is a typical specification when choosing a transformer
- The Hot Spot is the buffer added for internal hot spots
- For large power transformers, an 80 °C temp rise will cost more than a 150 °C, and will likely last longer
- Designing for other ambient temperatures like 50 °C for use in desert regions will increase the cost
- Lower coil temp rise = higher price
- Higher ambient temp requirement = higher price

Type QL insulation system

- Insulation Class: 220 °C, UL recognized insulation system with a maximum of 150, 115 or 80 °C rise above 40 °C ambient temperature
- Temperature rise ratings are in accordance with UL 1561
- All ABB Type QL dry type transformers use a 220 °C insulation rating class

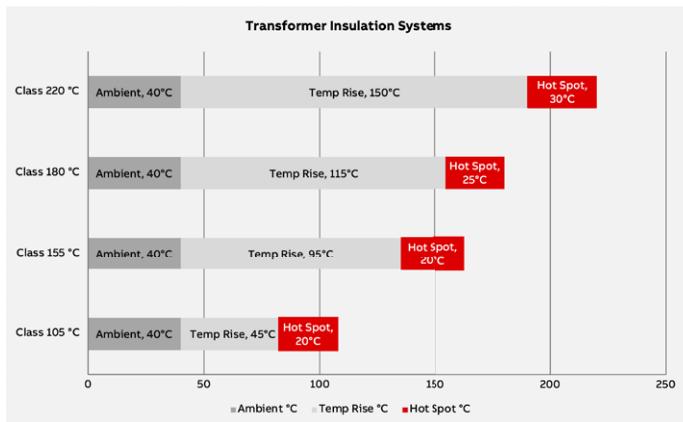

Single phase transformer data

Typical data based upon single-phase 240X480 V primary and 120/240 V secondary
DOE 2016 and NRCan efficient dry type transformers for three-wire or two-wire secondary applications

Conductor	Temp. Rise	Catalog Number	kVA	Frame	Weight (lb.)	Losses in Watts			Efficiency (T Rise +20)				Full Load	
						No Load	Impedance Loss	Total at Rise +20 °C	25%	35%	50%	75%		
Aluminum Wound	150 °C Rise	9T33A2670	15	YX171	320	71.2	524.7	595.8	97.51	97.7	97.78	97.45	96.98	
		9T33A2671	25	YX171	320	98.8	852.2	951.0	97.83	98.00	97.97	97.61	97.13	
		9T33A2672	37.5	YX172	460	133.9	1156.7	1290.7	98.40	98.20	98.18	97.86	97.43	
		9T33A2673	50	XV173	490	150.8	1643.1	1793.9	98.21	98.30	98.20	97.80	97.31	
		9T33A2674	75	YX174	600	206.4	2187.5	2394	98.37	98.50	98.41	98.07	97.65	
		9T33A2675	100	YX175	950	233.8	20601.3	2835.1	98.57	98.60	98.53	98.18	97.76	
	80 °C Rise	9T33A2674G80	75	YX175	950	233.8	1226.1	1459.9	98.40	98.60	98.63	98.46	98.2	
	Copper Wound	150 °C Rise	9T33C2670	15	YX171	350	71.2	528.6	599.8	97.50	97.70	97.76	97.42	96.94
			9T33C2671	25	YX171	350	98.8	810.2	909.0	97.85	98.00	98.02	97.69	97.23
			9T33C2672	37.5	YX172	510	119.6	1298.2	1417.8	98.11	98.20	98.10	97.69	97.17
9T33C2673			50	XV173	500	150.8	1303.5	1454.3	98.33	98.30	98.45	98.17	97.80	
9T33C2674			75	YX174	750	206.4	1898.8	2105.2	98.45	98.5	98.53	98.25	97.89	

Table continued below

Typical data based upon single-phase 240X480 V primary and 120/240 V secondary
DOE 2016 and NRCan efficient dry type transformers for three-wire or two-wire secondary applications (continued)

Conductor	Temp. Rise	Catalog Number	kVA	% Regulation			% Imp. T rise +20 °C	% X T rise +20 °C	R T rise +20 °C	X/R Ratio	Sound Level dB (per NEMA ST-20)
				100% PF	80% PF						
Aluminum Wound	150 °C Rise	9T33A2670	15	3.7	4.9	4.7	3.1	3.5	0.9	45	
		9T33A2671	25	3.6	5.4	5.3	3.9	3.4	1.2	45	
		9T33A2672	37.5	3.3	5.6	5.4	4.7	3.1	1.5	45	
		9T33A2673	50	3.5	5.4	5.4	4.1	3.3	1.3	45	
		9T33A2674	75	3.2	5.9	6.0	5.3	2.9	1.8	50	
		9T33A2675	100	2.7	5.2	5.8	5.2	2.9	1.8	50	
	80 °C Rise	9T33A2674G80	75	1.7	3.5	4.5	3.88	2.19	1.8	50	
	Copper Wound	150 °C Rise	9T33C2670	15	3.7	4.3	4.2	2.2	3.5	0.6	45
			9T33C2671	25	3.4	4.6	4.5	3.0	3.2	0.9	45
			9T33C2672	37.5	3.7	6.1	6.0	4.9	3.5	1.4	45
9T33C2673			50	2.8	4.7	4.7	3.9	2.6	1.5	45	
9T33C2674			75	2.7	5.5	5.9	5.3	2.5	2.1	50	

Single phase transformer data

Typical data based upon single phase 240X480 V primary and 120X240 V secondary
DOE 2016 efficient dry type transformers for two wire secondary applications

Conductor	Temp. Rise	kVA	Frame	Weight (lb.)	Losses in Watts			Efficiency (T Rise +20)					
					No Load	Impedance Loss	Total at Rise +20 °C	25%	35%	50%	75%	Full Load	
Aluminum Wound	150 °C Rise	15	XV171	320	62.5	669.2	731.7	97.6	97.7	97.64	97.15	96.54	
		25	YF171	320	101.7	833.8	935.5	97.82	98	98.03	97.72	97.28	
		37.5	YF171	320	109.3	1404.1	1513.4	98.2	98.2	98.12	97.66	97.12	
		50	YF172	400	142.5	1719.3	1861.8	98.27	98.3	98.23	97.82	97.32	
		75	YF174	510	206.4	2014.5	2220.9	98.42	98.5	98.47	98.17	97.78	
		100	YF175	900	253.7	2385	2638.7	98.56	98.6	98.62	98.36	98.01	
		167	YF176	1420	396.6	3473.8	3870.4	98.69	98.7	98.78	98.57	98.28	
		250	YF177	1700	544.3	5088.1	5632.4	98.76	98.8	98.82	98.59	98.29	
	115 °C Rise	15	XV171	320	90.2	279.6	369.8	97.3	97.7	98.1	98.13	97.96	
		25	YF171	320	109.3	592.3	701.6	97.83	98	98.22	98.05	97.74	
		37.5	YF172	400	142.5	900.8	1043.3	98.04	98.2	98.32	98.1	97.76	
		50	XV173	490	150.8	1494.8	1645.6	98.23	98.3	98.23	97.85	97.38	
		75	YF174	510	206.4	1784.4	1990.8	98.44	98.5	98.5	98.2	97.82	
		100	YF175	900	253.7	2097.4	2351.1	98.58	98.6	98.65	98.4	98.06	
	80 °C Rise	15	YF171	320	109.3	200	309.3	96.89	97.7	97.99	98.18	98.13	
		25	YF171	320	109.3	553.5	662.8	97.71	98	98.18	97.99	97.66	
		37.5	YF172	400	142.2	807.1	949.3	98.03	98.2	98.3	98.07	97.72	
		50	YF174	510	206.4	754.2	960.6	98.04	98.3	98.2	97.8	97.3	
		100	YF176	1420	260	1872.2	2132.2	98.55	98.6	98.64	98.39	98.06	
	Copper Wound	150 °C Rise	15	YF171	350	90.2	301.1	391.3	97.31	97.7	98.11	98.15	97.99
			25	YF171	350	109.3	766	875.3	97.75	98	98.06	97.81	97.42
			37.5	YF172	460	126.4	1119.9	1246.3	98.15	98.2	98.27	97.97	97.56
			50	XV173	500	150.8	1251.1	1401.9	98.3	98.3	98.37	98.06	97.66
			75	YF174	625	225.3	1687.3	1912.6	98.39	98.5	98.56	98.34	98.02
100			YF175	900	253.7	2326.8	2580.5	98.56	98.6	98.62	98.35	98	
167			YF176	1675	396.6	3265.1	3661.7	98.7	98.7	98.8	98.59	98.31	
250			YF177	1960	474.2	5094.7	5568.9	98.82	98.8	98.76	98.45	98.09	
115 °C Rise		15	YF171	350	90.2	277.9	368.1	97.3	97.7	98.1	98.13	97.96	
		25	YF171	350	103.8	693.7	797.5	97.83	98	98.1	97.84	97.44	
		37.5	YF172	460	126.4	1021.9	1148.3	98.14	98.2	98.27	97.96	97.54	
		50	XV173	500	150.8	1149.1	1299.9	98.35	98.3	98.48	98.23	97.87	
		75	YF174	625	225.3	1542.7	1768	98.39	98.5	98.56	98.34	98.02	
		100	YF175	900	253.7	2148	2401.7	98.56	98.6	98.61	98.34	97.98	
80 °C Rise		167	YF176	1675	396.6	3220.5	3617.1	98.65	98.7	98.7	98.44	98.11	
		15	YF171	350	90.2	250.3	340.5	97.3	97.7	98.09	98.12	97.96	
		25	YF171	350	103.8	693.7	797.5	97.83	98	98.1	97.84	97.44	
		37.5	YF172	460	126.4	946.8	1073.2	98.13	98.2	98.23	97.91	97.48	
		50	YF174	625	225.3	636.5	861.8	97.95	98.3	98.53	98.54	98.4	
		75	YF175	900	253.7	1118.4	1372.1	98.33	98.5	98.65	98.54	98.31	
		100	YF176	1675	396.6	950.8	1347.4	98.23	98.6	98.79	98.83	98.75	

Table continued on next page

Single phase transformer data

Typical data based upon single phase 240X480 V primary and 120X240 V secondary
DOE 2016 efficient dry type transformers for two wire secondary applications (continued)

Conductor	Temp. Rise	kVA	% Regulation		% Imp. T rise +20 °C	% X T rise +20 °C	R T rise +20 °C	X/R atio	Sound Level dB (per NEMA ST-20)	
			100% PF	80% PF						
Aluminum Wound	150 °C Rise	15	4.5	5.7	5.6	3.5	4.4	0.8	45	
		25	3.4	5.1	5.1	3.9	3.3	1.2	45	
		37.5	4	7.1	7.7	6.7	3.7	1.8	45	
		50	3.6	6.3	6.7	5.8	3.4	1.7	45	
		75	2.9	6	6.2	5.6	2.7	2.1	50	
		100	2.6	6.3	6.6	6.1	2.4	2.5	50	
		167	2.2	4.1	4.6	4.1	2.1	2.0	50	
	250	2.3	5.7	7	6.7	2	3.4	55		
	115 °C Rise	15	1.9	3.5	3.8	3.3	1.9	1.7	45	
		25	2.5	4.6	5	4.4	2.4	1.8	45	
		37.5	2.5	4.6	5	4.4	2.4	1.8	45	
		50	3.1	5	5.2	4.3	3	1.4	45	
		75	2.5	5.2	6	5.5	2.4	2.3	50	
		100	2.3	5.4	6.5	6.1	2.1	2.9	50	
	80 °C Rise	15	1.4	2.6	2.9	2.6	1.3	2.0	45	
		25	2.3	4.4	4.9	4.4	2.2	2.0	45	
		37.5	2.2	4.4	4.9	4.4	2.2	2.0	45	
		50	1.6	3.5	4.1	3.8	1.5	2.5	45	
		100	1.9	3.8	4.2	3.8	1.9	2.0	50	
	Copper Wound	150 °C Rise	15	2	3.2	3.3	2.6	2	1.3	45
			25	3.2	5.2	5.6	4.7	3.1	1.5	45
			37.5	3.1	5.2	5.1	4.1	3	1.4	45
			50	2.7	4.7	4.7	3.8	2.7	1.4	45
			75	2.4	4.8	5.5	5	2.2	2.3	50
100			2.5	5	5.6	5.1	2.3	2.2	50	
167			2	4	4.0	3.5	2	1.8	50	
250		2.2	5.5	6.7	6.4	2	3.2	55		
115 °C Rise		15	1.9	3.1	3.3	2.7	1.9	1.4	45	
		25	2.9	5.2	5.7	5	2.8	1.8	45	
		37.5	2.8	4.7	5	4.2	2.7	1.6	45	
		50	2.6	4.8	4.6	4	2.3	1.7	45	
		75	2.2	4.6	5.3	4.9	2.1	2.3	50	
		100	2.3	4.8	5.5	5.1	2.1	2.4	50	
	167	2	4	4.4	4	1.9	2.1	50		
80 °C Rise	15	1.6	2.9	3.2	2.7	1.7	1.6	45		
	25	2.9	5.2	5.6	4.9	2.8	1.8	45		
	37.5	2.6	5	5.6	5	2.5	2.0	45		
	50	1.3	3	3.5	3.3	1.3	2.5	45		
	75	1.6	3.5	4.1	3.8	1.5	2.5	50		
	100	1	2	2.3	2.1	1	2.1	50		

Three phase transformer data

Typical Data based upon 480 V delta primary and 208Y/120 secondary
DOE 2016 efficient dry type transformers K-Factor 1

Conductor	Temp. Rise	kVA	Frame	Weight		Losses in Watts		Efficiency (T Rise +20)					
				Painted	Stainless Steel	No Load	Impedance Loss	Total at Rise +20 °C	25%	35%	50%	75%	Full Load
Aluminum Wound	150 °C Rise	15	UX71A	231	251	63.0	471.3	534.3	97.81	97.89	98.09	97.82	97.42
		30	UY72A	297	217	78.7	1191.3	1270	98.28	98.23	98.11	97.6	97.02
		45	UX73A	363	383	120.8	1395.2	1516	98.4	98.4	98.38	98.01	97.57
		75	UY04A	555	575	168.8	2275.1	2443.9	98.58	98.6	98.49	98.12	97.67
		112.5	DY75A	680	760	245.5	2815.3	3060.8	98.69	98.74	98.67	98.37	98.01
		150	DY76A	1030	1050	322	2931.9	3253.9	98.79	98.83	98.85	98.63	98.34
		225	DY77A	1450	NA	377.2	5080.9	5458.1	98.92	98.94	98.83	98.52	98.17
		300	DY08A	1666	NA	465	6348.5	6813.5	99.01	99.02	98.93	98.66	98.34
	500	DY79A	2713	NA	698.5	8454.7	9153.2	99.13	99.14	99.09	98.87	98.6	
	115 °C Rise	15	UX71A	231	251	63	434.3	497.3	97.8	97.89	98.06	97.79	97.38
		30	UX72A	330	350	77.7	1100.2	1177.9	98.27	98.23	98.07	97.55	96.95
		45	UX73A	444	464	143.2	1029.3	1172.5	98.3	98.4	98.48	98.25	97.92
		75	UX74A	603	623	168.8	1920.5	2089.3	98.61	98.6	98.54	98.19	97.77
		112.5	DX75A	830	850	230.8	2705.7	2936.5	98.71	98.74	98.65	98.31	97.91
		150	DX76A	1250	NA	318.4	2835.7	3154.1	98.79	98.83	98.84	98.61	98.32
		225	DX77A	1670	NA	425	4087.1	4512.1	98.88	98.94	98.88	98.64	98.33
		300	DX78A	1985	NA	480.3	5265.3	5745.6	99.01	99.02	98.97	98.73	98.43
	500	DX79A	2900	NA	719	7032.9	7751.9	99.14	99.14	99.13	98.94	98.7	
	80 °C Rise	15	UY72A	297	317	78.7	247.3	326	97.6	97.89	98.26	98.25	98.07
		30	UY73A	363	383	120.6	531.7	652.3	98.04	98.23	98.44	98.32	98.07
		45	UY04A	555	575	168.8	666.3	835.1	98.2	98.4	98.61	98.54	98.34
		75	DY75A	680	760	245.5	1042.4	1287.9	98.41	98.6	98.74	98.65	98.46
		112.5	DY76A	1030	1050	304.3	1346.1	1650.4	98.67	98.74	98.93	98.85	98.67
		150	DY77A	1450	NA	366.2	1855.7	2221.9	98.76	98.83	98.97	98.85	98.66
225		DX78A	1985	NA	480.3	2718.7	3199	98.89	98.94	99.04	98.91	98.71	
300		DY79A	2713	NA	698.5	2550.6	3249.1	98.89	99.02	99.15	99.12	99	
Copper Wound	150 °C Rise	15	UX71C	230	250	55.1	572.2	627.3	97.89	97.89	97.95	97.53	97
		30	UX72C	353	373	92	986.5	1078.5	98.22	98.23	98.24	97.87	97.41
		45	UX73C	480	500	139.6	1109.3	1248.9	98.34	98.4	98.51	98.28	97.94
		75	UY04C	503	523	200.9	791.4	992.3	98.52	98.6	98.62	98.38	98.05
		112.5	DY75C	790	870	245.9	2805.1	3051	98.69	98.74	98.67	98.37	98
		150	DY76C	1085	1105	304.1	3373.8	3677.9	98.79	98.83	98.77	98.5	98.16
		225	DY77C	1610	NA	449.7	4340.5	4790.2	98.86	98.94	98.9	98.68	98.39
		300	DY78C	1970	NA	478.2	5844.3	6322.5	99.01	99.02	98.97	98.72	98.42
	500	DX79C	3720	NA	758	7647.2	8405.2	99.1	99.14	99.09	98.89	98.64	
	115 °C Rise	15	UX71C	230	250	55.1	528.6	583.7	97.88	97.89	97.92	97.49	96.95
		30	UX72C	353	373	92	899	991	98.21	98.23	98.23	97.86	97.39
		45	UX73C	480	500	134.5	1101.6	1236.1	98.35	98.4	98.45	98.18	97.81
		75	UX74C	748	768	213	1352	1565	98.52	98.6	98.72	98.55	98.29
		112.5	DX75C	900	980	280.8	1982.9	2263.7	98.67	98.74	98.81	98.63	98.37
		150	DX76C	1240	1260	293.6	3309	3602.6	98.78	98.83	98.73	98.42	98.04
		225	DX77C	1847	NA	513.5	3073.3	3586.8	98.8	98.94	98.96	98.82	98.60
		300	DX78C	2150	NA	544.9	4571.1	5116	98.97	99.02	99.03	98.84	98.6
	500	DX79C	3720	NA	758	6996.6	7754.6	99.1	99.14	99.1	98.9	98.65	
	80 °C Rise	15	UX72C	353	373	92	189	281	97.34	97.89	98.25	98.37	98.3
		30	UX73C	480	500	134.5	442.4	576.9	97.92	98.23	98.47	98.45	98.28
		45	UY74C	661	681	196.9	518.9	715.8	98.03	98.4	98.63	98.66	98.55
		75	DY75C	790	870	245.9	1042.2	1288.1	98.4	98.6	98.74	98.65	98.46
		112.5	DY76C	1085	1105	304.1	1594.3	1898.4	98.61	98.74	98.83	98.7	98.47
		150	DY77C	1610	NA	442.1	1623.1	2065.2	98.6	98.83	98.93	98.89	98.74
225		DX78C	2150	NA	544.9	2314.3	2859.2	98.81	98.94	99.06	98.99	98.84	
300		DX79C	3720	NA	758	2404	3162	98.81	99.02	99.12	99.1	98.99	

Table continued on next page

Three phase transformer data

Typical Data based upon 480 V delta primary and 208Y/120 secondary
DOE 2016 efficient dry type transformers K-Factor 1 (continued)

Conductor	Temp. Rise	KVA	% Regulation		% Imp. T rise +20 °C	% X T rise +20 °C	R T rise +20 °C	X/R Ratio	Sound Level dB (per NEMA ST-20)
			100% PF	80% PF					
Aluminum Wound	150 °C Rise	15	3.2	3.7	3.7	1.9	3.1	0.6	45
		30	4	4.6	4.6	2.4	4	0.6	45
		45	3.2	4.2	4.3	3	3.1	1.0	45
		75	3.1	4.5	4.6	3.5	3	1.2	50
		112.5	2.6	4	4.1	3.3	2.5	1.3	50
		150	2	3.9	4.4	3.9	2	2.0	50
		225	2.4	5.1	5.2	4.7	2.3	2.0	55
		300	2.2	4	4.3	3.8	2.1	1.8	55
		500	1.5	3.8	5.1	4.7	1.9	2.5	60
	115 °C Rise	15	2.9	3.5	3.4	1.8	2.9	0.6	45
		30	3.7	4.9	4.9	3.3	3.7	0.9	45
		45	2.3	3	3	2	2.3	0.9	45
		75	2.7	5.4	5.4	4.7	2.6	1.8	50
		112.5	2.6	5.3	5.2	4.6	2.4	1.9	50
		150	1.9	3.4	3.6	3.1	1.9	1.6	50
		225	1.9	4.5	4.7	4.3	1.8	2.4	55
		300	1.9	4.4	5.1	4.8	1.8	2.7	55
		500	1.5	3.8	5.4	5.2	1.4	3.7	60
	80 °C Rise	15	4	4.6	2	1.2	1.6	0.8	45
		30	1.8	2.6	2.6	1.9	1.8	1.1	45
		45	3.1	4.5	2.6	2.1	1.5	1.4	45
		75	1.4	2.4	2.6	2.2	1.4	1.6	50
		112.5	1.3	2.7	3.2	2.9	1.2	2.4	50
		150	2.4	5.1	3.8	3.6	1.2	3.0	50
		225	1.9	4.4	3.8	3.6	1.2	3.0	55
		300	1.5	3.8	3	2.9	0.9	3.2	55
		500	1.5	3.8	3	2.9	0.9	3.2	55
	Copper Wound	150 °C Rise	15	3.8	4	4.1	1.6	3.8	0.4
30			3.3	3.9	3.9	2.1	3.3	0.6	45
45			2.5	3	3	1.7	2.5	0.7	45
75			2.4	3.9	3	2.4	2.4	1.0	50
112.5			2.6	5	5	4.3	2.5	1.7	50
150			2.3	4.1	4.2	3.6	2.2	1.6	50
225			2	3.6	4.1	3.6	1.9	1.9	55
300			2.1	4.6	4.9	4.5	1.9	2.4	55
500			1.6	3.6	5.6	5.4	1.5	3.6	60
115 °C Rise		15	3.5	3.8	3.8	1.5	3.5	0.4	45
		30	3	3.7	3.6	2	3	0.7	45
		45	2.5	3.3	3.4	2.3	2.4	1.0	45
		75	1.8	3.3	3.5	3	1.8	1.7	50
		112.5	1.8	3.1	3.2	2.7	1.8	1.5	50
		150	2.3	4.9	5	4.5	2.2	2.0	50
		225	1.4	3.4	4	3.8	1.4	2.7	55
		300	1.7	4	4.5	4.2	1.6	2.6	55
		500	1.6	3.6	5	4.8	1.4	3.4	60
80 °C Rise		15	3	3.7	1.8	1.2	1.4	0.9	45
		30	1.5	2.1	2.2	1.6	1.5	1.1	45
		45	1.2	2.2	2.5	2.2	1.2	1.8	50
		75	2.6	5	3.2	2.9	1.4	2.1	50
		112.5	2.3	4.1	3.1	2.8	1.4	2.0	50
		150	1.1	2.3	2.4	2.1	1.1	1.9	55
		225	1.7	4	3.2	3	1	2.9	55
		300	1.6	3.6	3.4	3.3	0.8	4.1	55
		500	1.6	3.6	3.4	3.3	0.8	4.1	55

Sound levels

All general purpose transformers are as quiet, or quieter than required by NEMA ST-20. Average sound levels are warranted not to exceed the values listed for each load rating shown in the below table. Sound characteristics vary between transformers of identical voltage and kVA rating. The range of variation may be 4 to 8 decibels.

These values apply only to specified test conditions because the characteristic of the installation can cause them to be higher under operating conditions. Where acoustical noise is deemed to be of concern, proper steps should be taken during installation to minimize audible noise transmission. Please refer to the installation manual for installation and operation recommended practices to minimize the audible sound of the transformer.

If lower sound levels are needed or desired, -3 dB and -5 dB options are available for most models.

	Average Sound Level, Decibels	
	Self cooled ventilated	
	K-factor = 1 K-factor = 4	K-factor = 13 K-factor = 20
9.01 to 15.00	45	45
15.01 to 30.00	45	45
30.01 to 50.00	45	48
50.01 to 75.00	50	53
75.01 to 112.50	50	53
112.51 to 150.00	50	53
150.01 to 225.00	55	58
225.01 to 300.00	55	58
300.01 to 500.00	60	63
500.01 to 700.00	62	65
700.01 to 1000.00	64	67

Note 1: Consult factory for non-linear requirements exceeding a K-factor rating of 20.
Note 2: Sound levels are measured using the A-weighted scale (dB [A])

Electrostatic shielding

An electrostatic shield is a grounded insulated metallic foil inserted between the primary and secondary. The foil creates a shield effect which reduces the capacitive coupling between the windings, reducing the transmission of electrical noise between windings. All K-factor transformers (K4, K13, K20) and harmonic mitigating transformers come with electrostatic shielding. Electrostatic shielding can be ordered as an option for general purpose (K1) and is known as a Guard I transformer. See the suffix code table below for addition information on electrostatic shielding and noise reduction. All Type QL transformers that have electrostatic shielding use copper material for the shield.

Nomenclature

The nomenclature table is a guide to understanding our catalog numbers.

Please Note: This catalog number nomenclature is for illustrative purposes only. Not all catalog number combinations are available for production. Please reference the BuyLog Section 10 ordering tables beginning on page 10-10 for Three-phase DOE 2016 Efficiency transformers currently available for ordering. For additional assistance, please contact Customer Service at 1-800-431-7867.

DOE 2016 catalog number nomenclature

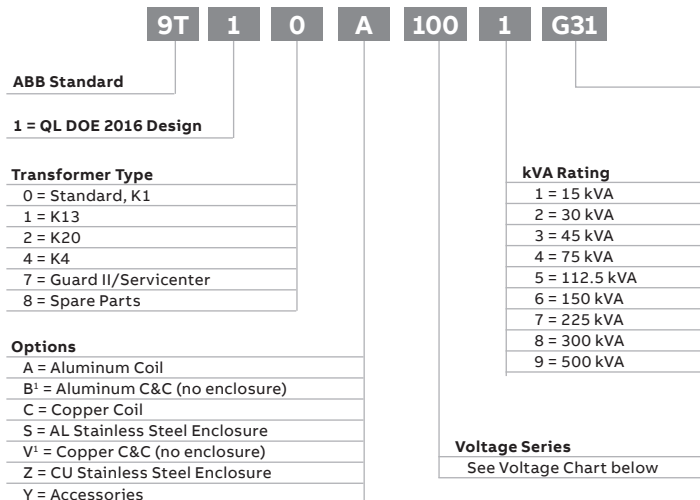

	Catalog No. Suffix Codes		
	Core & Coil Temp Rise		
	150 °C	115 °C	80 °C
Temp Rise Rating Only	G01 or blank	G31	G61
-3 dB noise reduction	G02	G32	G62
Electrostatic Shield*	G03	G33	G63
-3 dB noise reduction + Electrostatic Shield	G04	G34	G64
-5 dB noise reduction	G05	G35	G65
-5 dB noise reduction + Electrostatic Shield	G06	G36	G66

* An Electrostatic Shield (a Guard I transformer) is bonded to the ground terminal and is a copper barrier between the primary and secondary windings to reduce electrical noise. All K-factor transformers come standard with an Electrostatic Shield (K4, K13, K20).

*These options are UL recognized components.

3-phase common voltages

Series	Primary Voltage	Secondary Voltage
100	480	208Y/120
101	480	220
102	480	220Y/127
103	480	208
104	480	230Y/133
105	480	240Y/139
106	480	380
107	480	380Y/219
108	480	400Y/231
109	480	415Y/240
110	480	480
111	480	575
112	480	600
113	480	440Y/254
114	480	600Y/346
115	480	440
116	480	230/115
117	480	480Y/277
118	480	240/120
119	480	240
121	480	220/110
123	480	400
124	480	460
125	480	420
126	480	230
127	480	575Y/332
129	480	460Y/266
131	208	240
132	208	240/120
133	208	480
134	208	480Y/277
135	208	380Y/219
136	208	230
137	208	575
138	208	460
139	208	400Y/231
140	208	208
141	208	230Y/133
142	208	380
143	208	220/110
144	208	220Y/127
145	208	208Y/120
146	208	400
147	208	315
148	208	600
149	208	460Y/266
150	208	220
151	208	230/115
152	208	415Y/240
153	240	480Y/277
154	240	480
155	240	400Y/231

3-phase common voltages

Series	Primary Voltage	Secondary Voltage
157	240	575
158	240	460Y/266
159	240	240Y/139
160	240	600
161	240	208Y/120
162	240	380
163	240	440
164	240	240/120
165	240	380Y/219
166	220	380Y/219
167	220	400Y/231
168	220	240Y/139
169	220	220
170	220	208Y/120
171	220	480Y/277
172	220	440Y/254
173	220	480/240
174	220	480
175	220	415Y/240
176	380	220Y/127
177	380	480
178	380	220
179	380	208Y/120
180	380	415Y/240
181	380	240/120
184	380	480Y/277
185	380	380Y/219
186	380	230Y/133
187	380	240
188	440	220Y/127
189	440	480
190	440	208Y/120
191	440	380
192	440	380Y/219
193	440	400Y/231
194	440	575Y/332
195	440	240/120
196	440	480Y/277
197	440	240
198	230	460
199	230	400Y/231
200	230	400
201	230	480Y/277
202	230	208Y/120
203	230	480
204	400	230Y/133
205	400	380Y/219
206	400	480
207	400	220Y/127
209	400	400Y/231
210	400	208Y/120
211	400	208Y/120

3-phase common voltages

Series	Primary Voltage	Secondary Voltage
212	400	480Y/277
213	415	208Y/120
214	415	460
215	415	220Y/127
216	416	208Y/120
217	416	480Y/277
218	460	208Y/120
219	460	220
221	460	400Y/231
222	460	220Y/127
223	460	230
224	460	575Y/332
225	460	230Y/133
226	460	460Y/266
227	550	208Y/120
228	550	480Y/277
229	575	208Y/120
230	575	480Y/277
231	575	240Y/139
232	575	460
233	575	480
234	575	230Y/133
235	575	230
236	600	240/120
237	600	480
238	600	480Y/277
239	600	240
240	600	208Y/120
241	600	230Y/133
242	600	240Y/139
243	600	208
244	600	600Y/346
245	690	400Y/231
246	690	208Y/120
247	277	415Y/240
248	315	208Y/120
249	320	480Y/277
250	420	480Y/277
251	490	480Y/277
252	500	480Y/277

Mounting and placement

The only foundation necessary is a non-combustible flat surface strong enough to support the weight of the unit. Note that permanent and effective grounding of the metal case in accordance with NEC/CEC is recommended as a safety precaution.

Free circulation of ambient air is essential for the proper operation of all ventilated dry-type transformers. The top and sides of the transformer with ventilation openings require a minimum distance of six inches to adjacent noncombustible structures or equipment to ensure proper circulation of air. A minimum of six inches from the top of the enclosure is required for ventilation purposes, but 12 to 18 inches minimum is recommended for removal of top cover for servicing.

Larger kVA size transformers may require both front and rear access for installation and maintenance. Please refer to associated outline drawings that indicate terminal locations to determine if both front and rear access are needed.

Ventilation

Dry type general purpose transformers are cooled by free circulation of surrounding air. They depend on air to enter at the bottom, flow upward over the core and coil surfaces and exit through the openings near the top. These transformers will carry full-rated loads continuously when the surrounding air does not exceed 30 °C/86 °F average, 40 °C/104 °F maximum and adjacent structures permit free movement of cooling air.

The room in which dry type transformers are located should be sized to permit locating transformers with sufficient spacing between units and sufficient clearances to walls and other obstructions to permit the free circulation of air around each unit and to minimize noise amplification. Sufficient space should also be maintained to permit routine inspection and maintenance. Adequate ventilation is essential for the proper cooling of transformers. Clean dry air is desirable. Filtered air at or above atmospheric pressure may reduce maintenance if dust or other contaminants present a problem. When transformers are located in rooms or other restricted spaces, sufficient ventilation should be provided to hold the air temperature within established limits (30 °C/86 °F average over 24 hours with a 40 °C/104 °F maximum) when measured near the transformer inlets.

Cable conduit entrance / lugs

All cable connections to the transformer should be brought into the enclosure as low as possible to allow for the required cable bending radius. Side entry of cables is recommended as it leaves the ventilation areas unobstructed. When making cable connection or changing taps, always use two wrenches for tightening or loosening bolted connections to prevent distortion or damage.

Note: Terminals must be cleaned if it is necessary to change taps. Gently scrape the insulation/coating from the new connection and apply an electrical joint compound.

All general purpose transformers are designed for easy accommodation of cables and cable connectors. Lug connector kits are readily available and can be ordered through the sales office, through the distributor, or can be purchased commercially. Lug kit and ground bar kits are included up through 150 kVA. The assembly of connectors to the line terminals is important. Follow established installation procedures recommended by the connector manufacturer. Do not install washers between the lug and the terminal as this will cause heating and arcing, resulting in failure of the connector. Refer to the NEC/CEC guide for sizing. Follow the torque recommendations of the connector manufacturer or use the guide below.

Bolt Size	Torque (in lbs.)
1/4"	60
5/16"	120
3/8"	220
1/2"	460

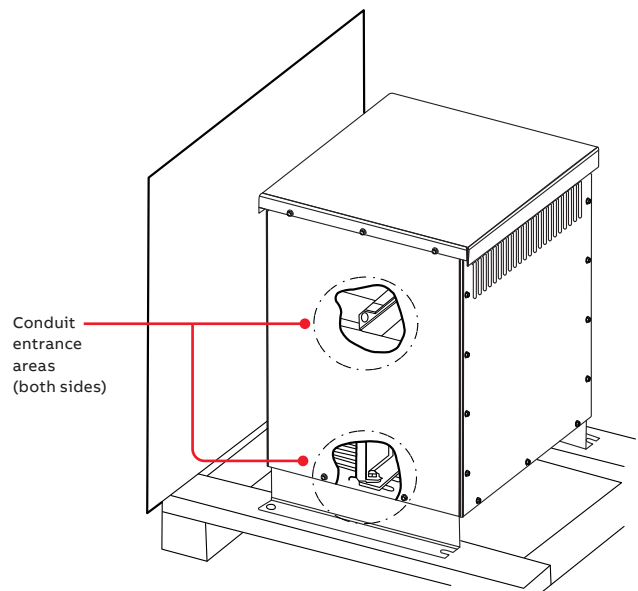

Cleaning and maintenance

Under normal environments and operating conditions, dry type transformers are virtually maintenance-free. However, they do require occasional internal cleaning, care, and inspection. The frequency of inspection, cleaning and care will depend on the atmospheric and/or environmental conditions where the transformer is installed.

A continuously energized transformer needs periodic cleaning and maintenance to remove accumulations of dust or dirt from cooling ducts and other surfaces. Large accumulations may reduce cooling efficiency and lead to overheating.

Maintenance and cleaning are recommended at least once a year in relatively clean installations and at more frequent intervals in more heavily contaminated atmospheres.

Transformers that are de-energized for long periods of time generally require more frequent maintenance and cleaning to ensure the removal of contamination.

CAUTION: Any internal inspection, adjustment, cleaning, or maintenance must be done with the transformer de-energized and the windings grounded. Technicians must follow NFPA 70E guidelines.

Cleaning

Accumulation of dirt on insulating surfaces becomes a hazard when a considerable amount of moisture is absorbed. Vacuuming is the recommended method for cleaning. Special attention should be given to cooling ducts within the winding. Low pressure dry air can be used if care is taken to avoid driving the contamination into the insulation.

Moisture is detrimental to most insulation systems. It is advisable to dry out any transformer that has been exposed for long periods of time to high humidity. Whenever moisture is visible on insulation surfaces, the unit must be dried before being energized. If moisture is evident, the unit should be dried out by placing it in an oven, by blowing heated air over it, or by placing strip heaters under the coil windings. The temperature of the heated air should not exceed 110 °C/230 °F. If strip heaters are used, the elements should not be allowed to come in contact with the transformer. Heat should be applied to both the front and rear of the transformer. Normal drying techniques may not be adequate for transformers subjected to flooding, direct rain or similar applications of water. The factory should be consulted as the transformer will most likely need to be replaced.

Maintenance

Maintenance would include dust removal and/or drying (if applicable), tap changing, tightening of bolted connections, general servicing and inspection of auxiliary devices. Additional information related to the installation and maintenance of general purpose transformers can be found in ANSI publication C57.94, "Guide for Installation and Maintenance of Dry Type Transformers."

Applicable design, performance and safety standards

ABB Dry Type Transformers conform to the standards as shown above and are in compliance with these standards below:

- ANSI/NFPA 70: National Electrical Code
- ANSI/IEEE C57.96, Distribution Transformers, Guide for Loading Dry Type appendix to ANSI C57.12 standards
- IEEE C57.12.01: General Requirements for Dry Type Distribution Transformers
- IEEE C57.12.91, Test Code for Dry Type Distribution Transformers
- NEMA ST-20: Dry Type Transformers for General Applications
- UL 1561, Dry Type General Purpose Power Transformer, UL Category code XQNX
- 10 CFR 431 (DOE2016) USA Efficiency Level compliance, UL category code ZXPC
- CSA 802.2 (Natural Resources Canada - NRCAN) energy efficiency compliance (UL category code ZZED)
- ANSI/UL 5085 Low Voltage Transformers, UL category code XPTQ
- UL Energy Verification – for US and Canada (ZXPC: EV519886) (ZZED: EV23760)
- ABB's dry type transformers are manufactured in an ISO 9001 certified plant.



Transformer's main components

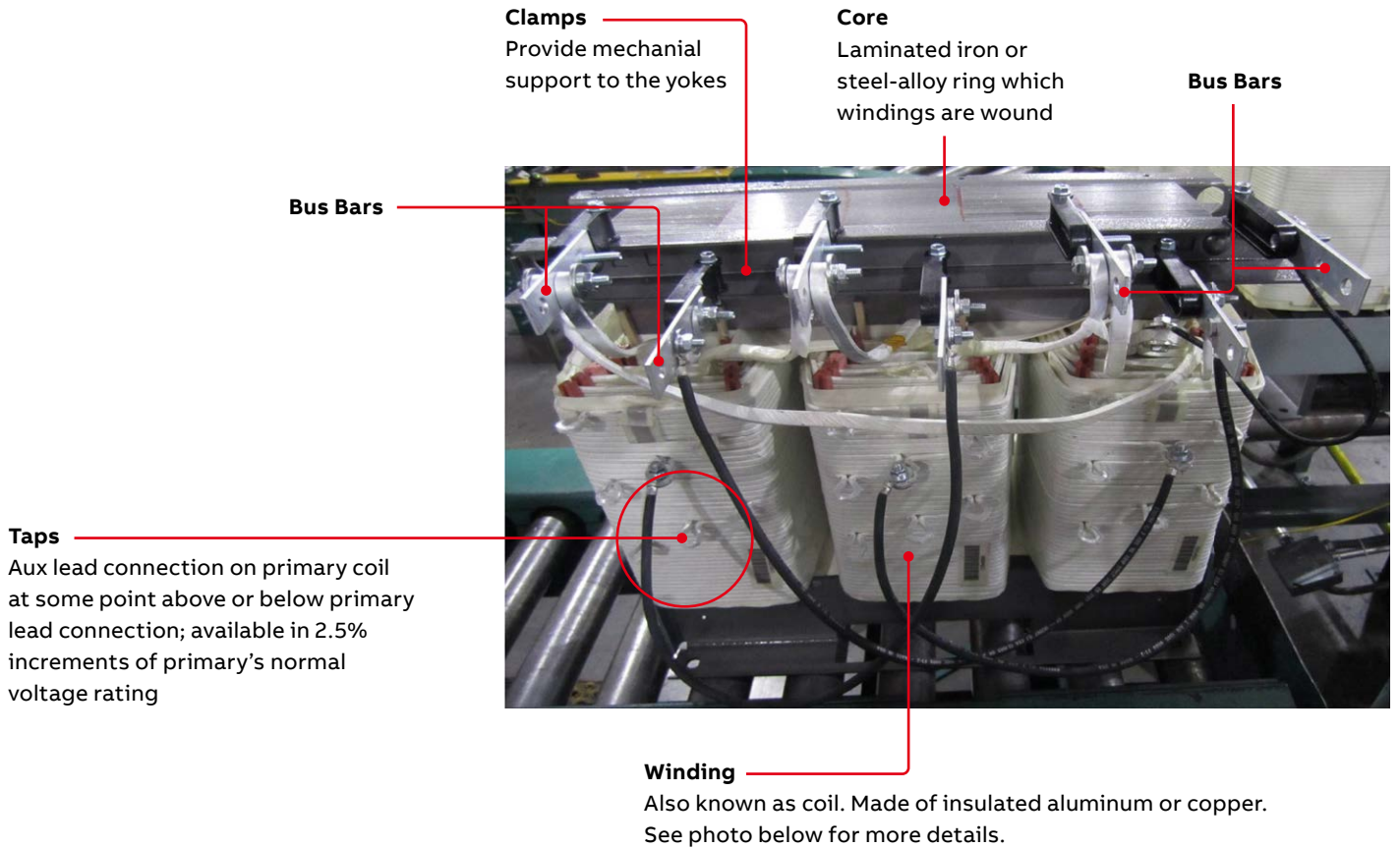

Transformer winding (also known as coil)

- Windings are coils of conductors
- Windings are made of insulated aluminum or copper
- Wrapped with Nomex paper or painted with varnish
- Cooling ducts are added to increase convection area
- Ducts are built by inserting spacers between conductor layers
- Taps allows the modification of voltage ratio by adding or subtracting turns of the primary winding

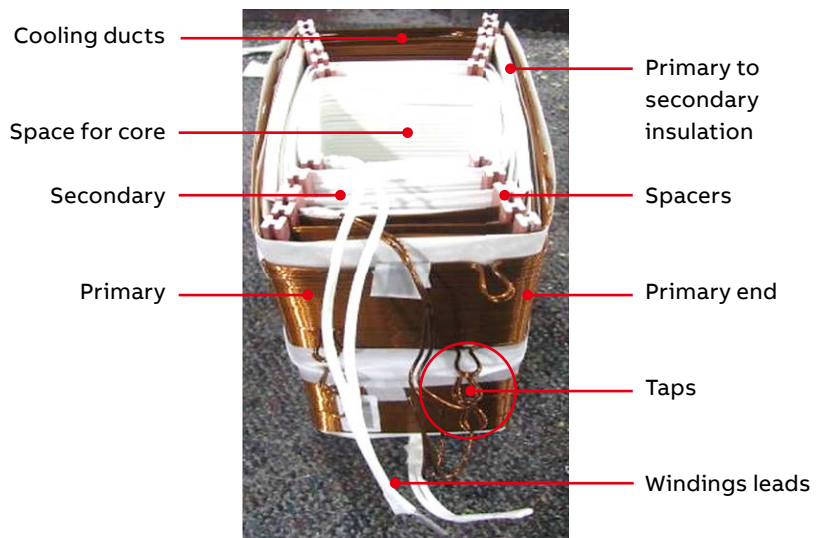

Seismic testing

The testing was performed according to both the requirements of ICC-ES AC156 and IEEE-693-2005 and meets the requirements for special seismic certification as detailed in section 1705A.13.3 of the CBC 2019 and the 2015-ICC-ES AC156 standard. In accordance with ASCE 7-16, which contains the seismic provisions of the 2018 International Building Code [IBC], AC156 is an acceptable test procedure for determining the seismic certification of equipment. ASCE 7-16, Section 13.2.1.2.b allows for testing alone to be used to satisfy all IBC seismic design requirements for electrical equipment.

Using AC156 procedures, third party engineering evaluation determined that the test results demonstrate the ability of the ABB low voltage transformers up to the peak ground seismicity (Sds) in the table below. Therefore, third party engineering evaluation concludes that the test data demonstrates that the ABB low voltage transformers are certified for installation in accordance with the seismic provisions of the 2018 IBC for any site with a site-specific Sds equal or less than the below Sds table and at any location within a building.

Enclosure Type & Product Names	Mounting	NEMA Rating	kVA	Width	Depth	Height	Weight	Sds (g)	IEEE-693 Seismic Level
Vented/Non-Vented QL Transformer	Floor	1, 2	11-1000	18" -47"	16" - 40"	27" - 57"	50- 4,290 lbs.	1.18 ¹ & 2.42 ²	High
QL Transformer	Wall Bracket	1, 2	11-112.5	19" - 32"	17" - 28"	27" - 39.9"	50- 1,018 lbs.	1.16 ¹ & 2.50 ²	High

¹For QL, QF, FC

²For encapsulated and enclosed Servicenter™ product line

Tests

Below are the production line tests we perform on each type QL transformer.

- HiPot test (Dielectric test)
- Induced volts test
- OCV (Open Circuit Volts, this is Volts ratio test)
- No load losses
- Load losses
- Impedance volts
- Excitation current
- Polarity test

These tests are pass/fail only.

HiPot (dielectric) testing is more strenuous than insulation resistance as it applies a higher voltage looking for insulation breakdown – it is a pass/fail test.

We do not run the less stringent insulation resistance test and take or calculate readings.

In fact the IEEE Std C57.12.91-2011 standard warns against using such test results to determine suitability.

Insulation resistance tests

Insulation resistance tests determine the insulation resistance from individual windings to ground or between individual windings. The insulation resistance is commonly measured in megohms but may be calculated from measurements of applied voltage and leakage current. The insulation resistance of electrical apparatus is of doubtful significance as compared with the dielectric strength. It is subject to wide variation with design, temperature, dryness, and cleanliness of the parts. When the insulation resistance falls below prescribed values, it can, in most cases, be brought up to the prescribed value by cleaning and drying the transformer. The insulation resistance, therefore, may afford a useful indication as to whether the transformer is in suitable condition for application of the more meaningful dielectric test.

NOTE 1: The significance of values of insulation resistance tests generally requires some interpretation, depending on the design, dryness, and cleanliness of the insulation involved. If a user decides to make insulation resistance tests, it is recommended that insulation resistance values be measured periodically (during maintenance shutdown) and that these periodic values be plotted. Substantial variation in the plotted values of insulation resistance should be investigated for cause.

NOTE 2: Insulation resistances may vary with applied voltage, and any comparison should be made with measurements at the same voltage.

Here is an example of our typical test data.

Many of these are available on our web page.

ABB Inc.
305 Gregson Drive
Cary, NC 27511
electrification.us.abb.com



**Industrial
Solutions**

TYPICAL TEST DATA
LV Dry Type Transformer

MODEL #: 9T10A1004

Underwriters' Laboratories Inc. Listed

RATINGS

KVA	75	Conductor	AL
Frequency (Hz)	60	Phase	3
Primary Voltage	480D +2, -4 (2.5% taps)	Secondary Voltage	208Y/120
Current Line Primary (A)	90.21	Current Line Secondary (A)	208.18
Frame	UY04A	Insulation System (°C)	220C
K Factor	1	Efficiency level	DoE 2016 (10CFR 431)
Temp. Rise (°C)	150	Average Sound Level (dB)	50

LOSS DATA @ 100% LOAD

Core Loss or No Load Loss @ 100% voltage (Watts)	168.8
Impedance Loss or Coil Loss @ Rise + 20 °C reference (Watts)	2,275.1
Total Loss @ Rise + 20 °C reference (Watts)	2,443.9

DIELECTRIC AND PRODUCTION TESTING

Induce Test @ Twice rated voltage 400 Hz per UL1561 and NEMA ST-20
 Hipot Test for High Voltage winding to Low Voltage and Ground @ 4000 volts 60 Hz, 60 Sec
 Hipot Test for Low Voltage winding to High Voltage and Ground @ 2500 volts 60 Hz, 60 Sec
 Polarity additive in accordance with UL1561 and NEMA ST-20

EFFICIENCY:

DoE 2016 (10CFR 431) Efficiency Level

<u>Load (%)</u>	<u>Efficiency (%)</u>
16	98.28
25	98.58
35	98.60
50	98.49
75	98.12
100	97.67

IMPEDANCE:

Impedance at reference temperature of Rise + 20 °C (Calculated)

%R	3.0
%X	3.5
%Z	4.6
X/R Ratio	1.2

REGULATION:

Regulation at reference temperature of Rise + 20 °C (Calculated)

<u>Power Factor</u>	<u>Regulation (%)</u>
1.0	3.1
0.9	4.3
0.8	4.5

REFERENCE VALUES:

Inrush Current (Calculated)	t= 8.33ms
Imax (RMS)	≈1298.00 A

by ABB

Accessories and lug kits

Single-phase and three-phase

Wall mount bracket

Frame Size	Catalog Number
UX71A	9T18Y1071G07
UX71C	9T18Y1071G07
UX72A	9T18Y1071G07
UX72C	9T18Y1071G07
UX73A	9T18Y1071G07
UX73C	9T18Y1071G07
UX74A	9T18Y1074G07
UX74C	9T18Y1074G07
UY04A	9T18Y1074G07
UY74A	9T18Y1074G07
UY74C	9T18Y1074G07
DX75C	9T18Y1074G07
DY75A	9T18Y1074G07
DY75C	9T18Y1074G07
YX171	9T18Y1071G07
YX172	9T18Y1074G07
XV173	9T18Y1074G07
YX174	9T18Y1074G07
YX175	Not available
YF171	9T18Y5042
YF172	9T18Y5043
YF174	9T18Y5043
YF175	Not available
YF176	Not available
YF177	Not available

Bottom pan

Frame Size	Catalog Number
DY08A	9T18Y1078G09
DX76A	9T18Y1077G09
DX77A	9T18Y1077G09
DX77C	9T18Y1077G09
DY77A	9T18Y1077G09
DY77C	9T18Y1077G09
DX78A	9T18Y1078G09
DX78C	9T18Y1078G09
DY78A	9T18Y1078G09
DY78C	9T18Y1078G09
DX79A	9T18Y1079G09
DY79A	9T18Y1079G09
DY79C	9T18Y1079G09
DX79C	9T18Y1079G09
YF175	9T18Y4504G77
YF176	9T18Y4504G79
YF177	9T18Y4504G79

316 stainless steel rain shield kit

Frame Size	Catalog Number
UX71A	9T18Y1171G06
UX71C	9T18Y1171G06
UX72A	9T18Y1172G06
UX73A	9T18Y1172G06
UX72C	9T18Y1172G06
UX73C	9T18Y1172G06
UY74A	9T18Y1174G06
UX74A	9T18Y1174G06
UY74C	9T18Y1174G06
UX74C	9T18Y1174G06
DY75A	9T18Y1174G06
DY75C	9T18Y1174G06
DX75C	9T18Y1174G06
DY76A	9T18Y1176G06
DY76C	9T18Y1176G06
DX75A	9T18Y1176G06
DX76C	9T18Y1176G06

Ground bar kit

Frame Size	Catalog Number
UY04A	9T18Y1074G11
UX71A	9T18Y1071G11
UX71C	9T18Y1071G11
UX72A	9T18Y1071G11
UX73A	9T18Y1071G11
UX72C	9T18Y1071G11
UX73C	9T18Y1071G11
UY74A	9T18Y1074G11
UX74A	9T18Y1074G11
UY74C	9T18Y1074G11
UX74C	9T18Y1074G11
DY75A	9T18Y1074G11
DY76A	9T18Y1074G11
DY75C	9T18Y1074G11
DY76C	9T18Y1074G11
DX75A	9T18Y1074G11
DX75C	9T18Y1074G11
DX76C	9T18Y1074G11

Rain shield kit

Frame Size	Catalog Number
UY04A	9T18Y1074G06
UX71A	9T18Y1071G06
UX71C	9T18Y1071G06
UX72A	9T18Y1072G06
UX72C	9T18Y1072G06
UX73A	9T18Y1072G06
UX73C	9T18Y1072G06
UY74A	9T18Y1074G06
UX74A	9T18Y1074G06
UY74C	9T18Y1074G06
UX74C	9T18Y1074G06
DY08A	9T18Y1077G06
DY75A	9T18Y1074G06
DY75C	9T18Y1074G06
DX75A	9T18Y1076G06
DX75C	9T18Y1074G06
DY76A	9T18Y1076G06
DY76C	9T18Y1076G06
DX76A	9T18Y1077G06
DX76C	9T18Y1076G06
DX77A	9T18Y1077G06
DX77C	9T18Y1077G06
DY77A	9T18Y1077G06
DY77C	9T18Y1077G06
DY78C	9T18Y1077G06
DY78A	9T18Y1077G06
DX78A	9T18Y1077G06
DX78C	9T18Y1077G06
DX79A	9T18Y1079G06
DX79C	9T18Y1079G06
DY79A	9T18Y1079G06
DY79C	9T18Y1079G06
YF171	9T18Y4317G05
YF172	9T18Y4317G06
YF173	9T18Y4317G06
YF174	9T18Y1074G06
YF175	9Y18Y4322G77
YX171	9T18Y1072G06
YX172	9T18Y1074G06
XV173	9T18Y1074G06
YX174	9T18Y1074G06
YX175	9T18Y4322G77
YF176	9T18Y4322G88
YF177	9T18Y4322G88

Lug kits for QL transformers

Frame Size	Catalog Number
UY04A	9T18Y1074G10
UX71A	9T18Y1071G10
UX71C	9T18Y1071G10
UX72A	9T18Y1072G10
UX73A	9T18Y1072G10
UX72C	9T18Y1072G10
UX73C	9T18Y1072G10
UY74A	9T18Y1074G10
UX74A	9T18Y1074G10
UY74C	9T18Y1074G10
UX74C	9T18Y1074G10
DY08A	9T18Y1078G10
DY75A	9T18Y1075G10
DY75C	9T18Y1075G10
DX75C	9T18Y1075G10
DY76A	9T18Y1076G10
DY76C	9T18Y1076G10
DX75A	9T18Y1076G10
DX76C	9T18Y1076G10
DY77A	9T18Y1077G10
DY77C	9T18Y1077G10
DX76A	9T18Y1077G10
DX77A	9T18Y1077G10
DX77C	9T18Y1077G10
DY78A	9T18Y1078G10
DY78C	9T18Y1078G10
DX78A	9T18Y1078G10
DX78C	9T18Y1078G10
DX79A	9T18Y1079G10
DX79C	9T18Y1079G10
DY79A	9T18Y1079G10
DY79C	9T18Y1079G10
YF171	9T18Y7240G02
YF172	9T18Y7241G03
YF174	9T18Y7240G03
YF175	9T18Y7242G07
YF176	9T18Y7242G05
YF177	9T18Y7242G05

Accessories and lug kits

Single-phase and three-phase

Single phase lug kits

Coil Material	Temp Rise	kVA	Frame Size	Primary Bus Bar Holes (Qty/Size)	Secondary Bus Bar Holes (Qty/Size)	Lug Kit	Cable Size	Stud Diameter	Lug	Qty
Aluminum/ Copper	115 or 150	15 or 25 37.5	YF171	(2) .406 dia	(2) .406 dia	9T18Y7240G02	250MCM-6	(1) 21/64	P250	8
		50	YF172	(2) .406 dia	(2) .406 dia	9T18Y7241G03	250MCM-6 350MCM-6	(1) 21/64 (1) 13/32	P250 P350	4 4
	150	75	YF174	(2) .406 dia	(2) .406 dia	9T18Y7240G03	250MCM-6	(1) 21/64	P250	12
		100	YF175	(2) .406 dia	(2) .406 dia	9T18Y7242G07	350MCM-6	(1) 13/32	P350	12
		167	YF176	(2) .406 dia	(2) .406 dia	9T18Y7242G05	350MCM-6 500MCM-4	(1) 13/32 (1) 13/32	P350 P500	8 12

Three phase lug kits

Coil Material	Temp Rise	kVA	Frame Size	Primary Bus Bar Holes (Qty/Size)	Secondary Bus Bar Holes (Qty/Size)	Lug Kit	Cable Size	Stud Diameter	Lug	Qty	
Aluminum	115 or 150	15	UX71A	(2) .406 dia	(2) .406 dia	9T18Y1071G10	1/0-14	(1) 17/64	P125	7	
		30	UX72A	(2) .406 dia	(2) .406 dia	9T18Y1072G10	250MCM-6	(1) 21/64	P250	7	
		45	UX73A	(2) .406 dia	(2) .406 dia	9T18Y1072G10	250MCM-6	(1) 21/64	P250	7	
		500	DX79A	(4) .563 dia	(6) .563 dia	9T18Y1079G10	350MCM-6 500MCM-4	(1) 13/32 (1) 13/32	P350 P500	9 24	
	150	75	UY74A UY04A	(2) .406 dia	(2) .406 dia	9T18Y1074G10	250MCM-6 350MCM-6	(1) 21/64 (1) 13/32	P250 P350	3 4	
		115	75	UX74A	(2) .406 dia	(2) .406 dia	9T18Y1074G10	250MCM-6 350MCM-6	(1) 21/64 (1) 13/32	P250 P350	3 4
	112.5		DY75A	(1) .563 dia	(2) .563 dia	9T18Y1075G10	350MCM-6	(1) 13/32	P350	7	
	150		DY76A	(1) .563 dia	(2) .563 dia	9T18Y1076G10	350MCM-6 500MCM-4	(1) 13/32 (1) 13/32	P350 P500	3 4	
	150		225	DY77A	(2) .563 dia	(4) .563 dia	9T18Y1077G10	350MCM-6 500MCM-4	(1) 13/32 (1) 13/32	P350 P500	6 8
			300	DY78A DY08A	(4) .563 dia	(6) .563 dia	9T18Y1078G10	350MCM-6 500MCM-4	(1) 13/32 (1) 13/32	P350 P500	6 2
			500	DY79A	(4) .563 dia	(6) .563 dia	9T18Y1079G10	350MCM-6 500MCM-4	(1) 13/32 (1) 13/32	P350 P500	9 24
				112.5	DX75A	(1) .563 dia	(2) .563 dia	9T18Y1076G10	350MCM-6 500MCM-4	(1) 13/32 (1) 13/32	P350 P500
	115		150	DX76A	(2) .563 dia	(4) .563 dia	9T18Y1077G10	350MCM-6 500MCM-4	(1) 13/32 (1) 13/32	P350 P500	6 8
		225	DX77A	(2) .563 dia	(4) .563 dia	9T18Y1077G10	350MCM-6 500MCM-4	(1) 13/32 (1) 13/32	P350 P500	6 8	
			300	DX78A	(2) .563 dia	(4) .563 dia	9T18Y1078G10	350MCM-6 500MCM-4	(1) 13/32 (1) 13/32	P350 P500	6 2
		Copper		150 or 115	15	UX71C	(2) .406 dia	(2) .406 dia	9T18Y1071G10	1/0-14	(1) 17/64
	30		UX72C		(2) .406 dia	(2) .406 dia	9T18Y1072G10	250MCM-6	(1) 21/64	P250	7
	45		UX73C		(2) .406 dia	(2) .406 dia	9T18Y1072G10	250MCM-6	(1) 21/64	P250	7
	150		75	UY74C	(2) .406 dia	(2) .406 dia	9T18Y1074G10	250MCM-6 350MCM-6	(1) 21/64 (1) 13/32	P250 P350	3 4
			115	75	UX74C	(2) .406 dia	(2) .406 dia	9T18Y1074G10	250MCM-6 350MCM-6	(1) 21/64 (1) 13/32	P250 P350
	150			112.5	DY75C	(1) .563 dia	(2) .563 dia	9T18Y1075G10	350MCM-6	(1) 13/32	P350
			150	DY76C	(1) .563 dia	(2) .563 dia	9T18Y1076G10	350MCM-6 500MCM-4	(1) 13/32 (1) 13/32	P350 P500	3 4
			225	DY77C	(2) .563 dia	(4) .563 dia	9T18Y1077G10	350MCM-6 500MCM-4	(1) 13/32 (1) 13/32	P350 P500	6 8
				300	DY78C	(4) .563 dia	(6) .563 dia	9T18Y1078G10	350MCM-6 500MCM-4	(1) 13/32 (1) 13/32	P350 P500
500			DY79C		(4) .563 dia	(6) .563 dia	9T18Y1079G10	350MCM-6 500MCM-4	(1) 13/32 (1) 13/32	P350 P500	9 24
			112.5	DX75C	(1) .563 dia	(2) .563 dia	9T18Y1075G10	350MCM-6	(1) 13/32	P350	7
115			150	DX76C	(1) .563 dia	(2) .563 dia	9T18Y1076G10	350MCM-6 500MCM-4	(1) 13/32 (1) 13/32	P350 P500	3 4
			225	DX77C	(2) .563 dia	(4) .563 dia	9T18Y1077G10	350MCM-6 500MCM-4	(1) 13/32 (1) 13/32	P350 P500	6 8
	300			DX78C	(2) .563 dia	(4) .563 dia	9T18Y1078G10	350MCM-6 500MCM-4	(1) 13/32 (1) 13/32	P350 P500	6 2
			600MCM-2	(1) 13/32	P600	6					

Enclosure parts

Enclosure kits

Frame Size	Catalog Number
UY04A	9T18Y1074
UX71A	9T18Y1071
UX71C	9T18Y1071
UX72A	9T18Y1072
UX73A	9T18Y1072
UX72C	9T18Y1072
UX73C	9T18Y1072
UY74A	9T18Y1074
UX74A	9T18Y1074
UY74C	9T18Y1074
UX74C	9T18Y1074
DY08A	9T18Y1078
DY75A	9T18Y1075
DY75C	9T18Y1075
DX75C	9T18Y1075
DY76A	9T18Y1076
DY76C	9T18Y1076
DX75A	9T18Y1076
DX76C	9T18Y1076
DY77A	9T18Y1077
DY77C	9T18Y1077
DX76A	9T18Y1077
DX77A	9T18Y1077
DX77C	9T18Y1077
DY78A	9T18Y1078
DY78C	9T18Y1078
DX78A	9T18Y1078
DX78C	9T18Y1078
DX79A	9T18Y1079
DY79A	9T18Y1009
DY79C	9T18Y1079

Front/back panel

Frame Size	Catalog Number
UY04A	9T18Y1074G03
UX71A	9T18Y1071G03
UX71C	9T18Y1071G03
UX72A	9T18Y1072G03
UX73A	9T18Y1072G03
UX72C	9T18Y1072G03
UX73C	9T18Y1072G03
UY74A	9T18Y1074G03
UX74A	9T18Y1074G03
UY74C	9T18Y1074G03
UX74C	9T18Y1074G03
DY08A	9T18Y1078G03
DY75A	9T18Y1075G03
DY75C	9T18Y1075G03
DX75C	9T18Y1075G03
DY76A	9T18Y1076G03
DY76C	9T18Y1076G03
DX75A	9T18Y1076G03
DX76C	9T18Y1076G03
DY77A	9T18Y1077G03
DY77C	9T18Y1077G03
DX76A	9T18Y1077G03
DX77A	9T18Y1077G03
DX77C	9T18Y1077G03
DY78A	9T18Y1078G03
DY78C	9T18Y1078G03
DX78A	9T18Y1078G03
DX78C	9T18Y1078G03
DX79A	9T18Y1079G03
DY79A	9T18Y1079G03
DY79C	9T18Y1079G03

Side panel

Frame Size	Catalog Number
UY04A	9T18Y1074G04
UX71A	9T18Y1071G04
UX71C	9T18Y1071G04
UX72A	9T18Y1072G04
UX73A	9T18Y1072G04
UX72C	9T18Y1072G04
UX73C	9T18Y1072G04
UY74A	9T18Y1074G04
UX74A	9T18Y1074G04
UY74C	9T18Y1074G04
UX74C	9T18Y1074G04
DY08A	9T18Y1078G04
DY75A	9T18Y1075G04
DY75C	9T18Y1075G04
DX75C	9T18Y1075G04
DY76A	9T18Y1076G04
DY76C	9T18Y1076G04
DX75A	9T18Y1076G04
DX76C	9T18Y1076G04
DY77A	9T18Y1077G04
DY77C	9T18Y1077G04
DX76A	9T18Y1077G04
DX77A	9T18Y1077G04
DX77C	9T18Y1077G04
DY78A	9T18Y1078G04
DY78C	9T18Y1078G04
DX78A	9T18Y1078G04
DX78C	9T18Y1078G04
DX79A	9T18Y1079G04
DY79A	9T18Y1009G04
DY79C	9T18Y1079G04

Cover (top) panel

Frame Size	Catalog Number
UY04A	9T18Y1074G05
UX71A	9T18Y1071G05
UX71C	9T18Y1071G05
UX72A	9T18Y1072G05
UX73A	9T18Y1072G05
UX72C	9T18Y1072G05
UX73C	9T18Y1072G05
UY74A	9T18Y1074G05
UX74A	9T18Y1074G05
UY74C	9T18Y1074G05
UX74C	9T18Y1074G05
DY08A	9T18Y1078G05
DY75A	9T18Y1074G05
DY75C	9T18Y1074G05
DX75C	9T18Y1074G05
DY76A	9T18Y1076G05
DY76C	9T18Y1076G05
DX75A	9T18Y1076G05
DX76C	9T18Y1076G05
DY77A	9T18Y1077G05
DY77C	9T18Y1077G05
DX76A	9T18Y1077G05
DX77A	9T18Y1077G05
DX77C	9T18Y1077G05
DY78A	9T18Y1078G05
DY78C	9T18Y1078G05
DX78A	9T18Y1078G05
DX78C	9T18Y1078G05
DX79A	9T18Y1079G05
DY79A	9T18Y1079G05
DY79C	9T18Y1079G05

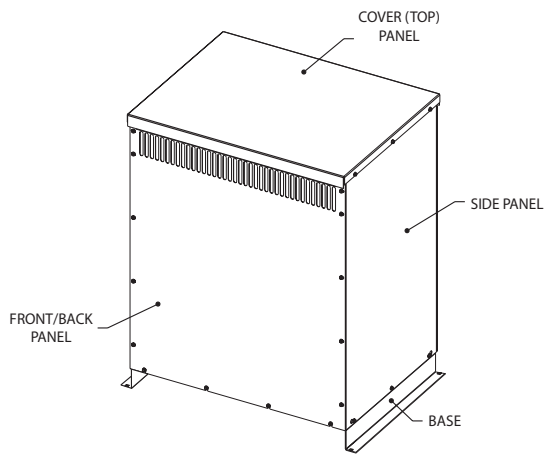

ENCLOSURE KIT: 1 COVER + 2 SIDES + 2 FRONTS

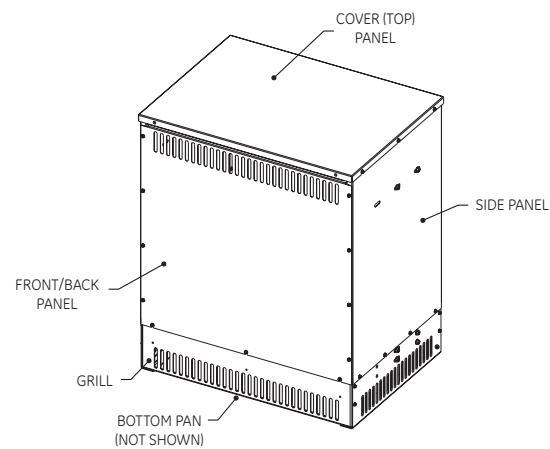

ENCLOSURE KIT: 1 COVER + 2 SIDES + 2 FRONTS

This style enclosure is used with the following frames:

Frame Size	Frame Size
UX71A	DY75A
UX71C	DY75C
UX72A	DX75A
UX72C	DX75C
UX73A	DY76A
UX73C	DY76C
UY74A	YF171
UX74A	YF172
UY74C	YF173
UX74C	YF174

This style enclosure is used with the following frames:

Frame Size	Frame Size
DX76A	DX78A
DX76C	DX78C
DX77A	DX79A
DX77C	DX79C
DY77A	YF175
DY77C	YF176
DY78C	YF177
DY78A	YX175

Dimensions

Single phase vented QL transformers

Product Weights and Dimensions		Approx. Weight (lb.)		Approx. Dimensions (in.)			Approx. Mounting Feet Dimensions	
Frame Size	Outline Drawing No.	AL	CU	Height (in.)	Width (in.)	Depth (in.)	Width (in.)	Depth (in.)
YF171	303B406AAP071	320	350	32	24	18	-	-
YF172	303B406AAP072	400	500	36	32	24	-	-
XV173	303B406AAP073	500	520	36	32	24	-	-
YF174	303B406AAP074	510	625	40	32	24	-	-
YF175	303B932AAP075	900	1050	37	30	29	-	-
YF176	303B932AAP076	1360	1675	46	39	33	-	-
YF177	303B932AAP077	1700	1960	46	39	33	-	-
YX171	303B409CAP071	320	350	35	27	19	26	16
YX172	303B409CAP072	460	510	36	35	24	34	21
XV173	303B409CAP073	490	500	36	35	24	34	21
YX174	303B409CAP074	600	750	43	35	24	34	21
YX175	303B409CAP075	950	N/A	38	33	29	31	23



QL Transformer
(Front Panel Removed)

Three phase, vented QL transformers

Includes General Purpose, K-factor, K-factor Low Noise, Low Noise, Guard I™, Midtapped, Drive Isolation

Product Weights and Dimensions		Enclosure Approx. Dimensions			Mounting Feet Approx. Dimensions		Approx. Weight	
Frame Size	Outline Drawing No.	Width (in.)	Depth (in.)	Height (in.)	Width (in.)	Depth (in.)	Painted (lbs.)	316 Stainless Steel (lbs.)
UX71A	303B111GEUXP71A	19	17	29	21	15	231	251
UX71C	303B111GEUXP71C	19	17	29	21	15	230	250
UX72A	303B111GEUXP72A	24	18	35	26	17	330	350
UX72C	303B111GEUXP72C	24	18	35	26	17	353	373
UX73A	303B111GEUXP73A	24	18	35	26	17	444	464
UY72A	303B111GEUYP72A	24	18	35	26	17	297	317
UY73A	303B111GEUYP73A	24	18	35	26	17	363	383
UX73C	303B111GEUXP73C	24	18	35	26	17	480	500
UY74A	303B111GEUYP74A	32	24	36	34	22	561	581
UY04C	303B111GEUYP04C	32	24	36	22	34	503	523
UY74C	303B111GEUYP74C	32	24	36	34	22	661	681
UX74A	303B111GEUXP74A	32	24	36	34	22	603	623
UX74C	303B111GEUXP74C	32	24	36	34	22	748	768
DY75A	303B111GEDYP75A	32	24	42	34	22	680	760
DY75C	303B111GEDYP75C	32	24	42	34	22	790	870
DX75A	303B111GEDXP75A	35	24	46	37	22	830	850
DX75C	303B111GEDXP75C	32	24	42	34	22	900	980
DY76A	303B111GEDYP76A	35	24	46	37	22	1030	1050
DY76C	303B111GEDYP76C	35	24	46	37	22	1085	1105
DX76A	303B112GEDXP76A	38	33	47	41	32	1250	NA
DX76C	303B111GEDXP76C	35	24	46	37	22	1240	1260
DY77A	303B112GEDYP77A	38	33	47	41	32	1450	NA
DY77C	303B112GEDYP77C	38	33	47	41	32	1610	NA
DX77A	303B112GEDXP77A	38	33	47	41	32	1670	NA
DY78A	303B112GEDYP78A	38	33	57	41	32	1670	NA
DX77C	303B112GEDXP77C	38	33	47	41	32	1847	NA
DY78C	303B112GEDYP78C	38	33	57	41	32	1970	NA
DX78A	303B112GEDXP78A	38	33	57	41	32	1985	NA
DX78C	303B112GEDXP78C	38	33	57	41	32	2150	NA
DX79A	303B112GEDXP79A	47	38	66	50	37	2900	NA
DX79C	303B112GEDXP79C	47	38	66	50	37	3720	NA
DY79A	303B112GEDYP79A	47	38	66	50	37	2713	NA

Single phase vented QL transformers

Package Weights and Dimensions		Approx. Weight (lb.)		Approx. Dimensions (in.)		
Frame Size	Outline Drawing No.	AL	CU	Height (in)	Width (in.)	Depth (in.)
YF171	303B406AAP071	362	392	38	27	30
YF172	303B406AAP072	448	548	42	30	35
XV173	303B406AAP073	548	568	42	30	35
YF174	303B406AAP074	741	673	46	30	35
YF175	303B932AAP075	925	1075	44	30	32
YF176	303B932AAP076	1415	1730	53	42	48
YF177	303B932AAP077	1755	2015	53	42	48
YX171	303B409CAP071	367	397	41	31	31
YX172	303B409CAP072	511	561	42	31	38
XV173	303B409CAP073	541	551	42	31	38
YX174	303B409CAP074	650	800	48	31	38
YX175	303B409CAP075	1005	NA	53	42	48

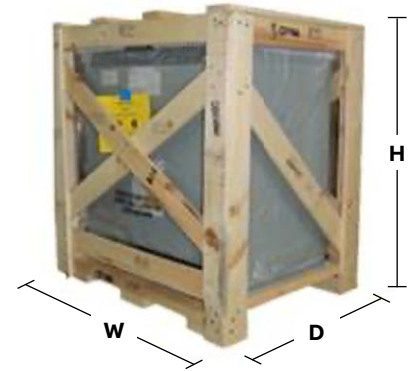

Three phase vented QL transformers

Package Weights and Dimensions		Approx. Weight (lb.)				Approx. Dimensions (in.)		
Frame Size	Outline Drawing No.	AL	AL-SS	CU	CU-SS	Height (in)	Width (in.)	Depth (in.)
UX71A	303B111GEUXP71A	268	288	NA	NA	35	26	31
UX71C	303B111GEUXP71C	NA	NA	267	287	35	26	31
UX72A	303B111GEUXP72A	377	397	NA	NA	41	30	31
UX72C	303B111GEUXP72C	NA	NA	400	420	41	30	31
UX73A	303B111GEUXP73A	491	511	NA	NA	41	30	31
UY72A	303B111GEUYP72A	344	364	NA	NA	41	30	31
UY73A	303B111GEUYP73A	410	430	NA	NA	41	30	31
UX73C	303B111GEUXP73C	NA	NA	527	547	41	30	31
UY74A	303B111GEUYP74A	598	618	NA	NA	35	26	31
UY04C	303B111GEUYP04C	NA	NA	554	574	42	30	38
UY74C	303B111GEUYP74C	NA	NA	712	732	42	30	38
UX74A	303B111GEUXP74A	654	674	NA	NA	42	30	38
UX74C	303B111GEUXP74C	NA	NA	799	819	42	30	38
DY75A	303B111GEDYP75A	730	810	NA	NA	48	30	38
DY75C	303B111GEDYP75C	NA	NA	840	920	48	30	38
DX75A	303B111GEDXP75A	888	NA	NA	908	52	30	41
DX75C	303B111GEDXP75C	NA	NA	950	1030	48	30	38
DY76A	303B111GEDYP76A	1088	1108	NA	NA	52	30	41
DY76C	303B111GEDYP76C	NA	NA	1143	1163	52	30	41
DX76A	303B112GEDXP76A	1305	NA	NA	NA	53	42	48
DX76C	303B112GEDXP76C	NA	NA	1298	1318	52	30	41
DX77A	303B112GEDXP77A	1725	NA	NA	NA	53	42	48
DY77C	303B112GEDYP77C	NA	NA	1665	NA	53	42	48
DX77A	303B112GEDXP77A	1655	NA	NA	NA	40	42	48
DY78A	303B112GEDYP78A	1725	NA	NA	NA	62	42	48
DX77C	303B112GEDXP77C	NA	NA	1902	NA	53	42	48
DY78C	303B112GEDYP78C	NA	NA	2025	NA	62	42	48
DX78A	303B112GEDXP78A	2040	NA	NA	NA	62	42	48
DX78C	303B112GEDXP78C	NA	NA	2205	NA	62	42	48
DX79A	303B112GEDXP79A	2964	NA	NA	NA	72	43	56
DX79C	303B112GEDXP79C	NA	NA	3784	NA	72	43	56
DY79A	303B112GEDYP79A	2777	NA	NA	NA	72	43	56

Selecting a transformer?

Key questions to ask

What is the kVA?

The maximum apparent power capacity of the transformer to deliver to its electrical loads, expressed as a number such as, 2, 15, 50 or 500 as examples.

What is the primary voltage?

The input voltage feeding the transformer, typically expressed as a number such as 480 followed by a V (480 V).

What is the secondary voltage?

The voltage(s) of the transformer that supply power to the electrical loads. Often shown as a power system such as a WYE (Y). 208Y/120 is common meaning both 208 volts and 120 volts can be delivered to electrical loads.

What is the frequency?

The periodic sinusoidal current delivered to the electrical loads and supplied to the primary of the transformer. In the United States 60 Hz is common according to ANSI C84.1 standard.

Are Taps required?

For example: +2, -4: 2.5%

What type of winding?

Aluminum or Copper

What is the required temperature rise?

80 °C, 115 °C, 150 °C

Are there non-linear loads?

If yes, use K-factor transformer. As a general rule, if 50% of the loads are expected to be non-linear, choose a K4 transformer. If the expected loads are beyond 50%, recommend a K13 transformer.

Are lower audible noise transformers required?

If yes, use Low Noise

What is the environment where the unit will be operating?

Indoor, Outdoor, Dusty, etc.

Glossary

BIL Rating - Basic Impulse Level; Indicates ability to withstand lightning strikes or high surge voltage exposure

Core - Laminated iron or steel-alloy ring which windings are wound around; Windings may be AL or CU

Coil - The windings of the transformer made of insulated copper or aluminum conductors

Frequency - The AC power cycles per second that the coil is designed to operate expressed in Hz – all 50 Hz can operate at 60 Hz but not the other way around!

xx% Imp - The amount of internal impedance at the frequency rating of the transformer, will determine available short circuit current and determine the voltage drop at full load. It is used to help size the circuit interrupting devices

Insulation Class (rating) - The maximum allowable temperature at any one point within the transformer (hot spot) that will give adequate life (≈20 years) before degradation starts.

kVA - (kilo-volt-ampere) Capacity of the transformer; defined as Output Voltage x Full-Load Output Current – how much power can it provide

Taps - Selectable, during installation, primary coil lead connections to accommodate supply voltages higher or lower than nominal that will provide the nameplate output or secondary voltage. Available in 2.5% increments of primary's normal voltage rating

Noise - Audible rating is given in decibels (abbreviated dB); Typical noise ranges are from 45 to 95 dB

Winding Temperature - The average temperature above ambient (40 °C) over time of that the coil (windings) will produce while operating at full load

Information annex

Differences between Cu and Al transformer

It is a common belief that copper coil transformers have greater efficiency than an aluminum coil transformer, since the electrical conductivity of copper is greater than aluminum. This common belief is not totally true. While copper does have better conductivity characteristics than aluminum, transformer designs must meet minimum efficiency ratings regardless of the metal used in its coils. However, there are some factors to consider regarding the coil winding materials beyond efficiency ratings.

Copper coil transformers are heavier, and copper is significantly a more expensive metal than aluminum. On the other hand, copper coil windings exhibit better withstand capabilities with short circuit events and vibration. This short circuit withstand capability can be an appreciable characteristic for applications where temporary short circuit loads can occur such as supplying power to numerous switch-mode power supplies.

Switch-mode power supplies in their normal operation generate transient short circuits during commutation (switching). These are not solid or “bolted” short circuits rather they are known as “high resistance” short circuits. These same transient short circuits induce electromechanical forces and vibrations within the winding which are better supported using copper conductors for the transformer coils.

As an example, any current induces an electromagnetic force on the windings. The electromagnetic force is increased with the square of the current. This means that in a short circuit event, the current is about 15 times the rated current, the forces induced at the windings are 237 times the force induced at full load conditions.

Therefore, specifying copper conductors for a transformer coil construction has its benefits for specific applications like switch-mode power supply (non-linear) loads. However, the additional costs and weight for such a transformer must be carefully considered. Aluminum coil transformers are an excellent choice for general purpose applications providing consistent performance over time with a long operational life. Both Aluminum and Copper coil transformers will provide the same efficiency ratings required by standards and law.

Typical 6-pulse SMPS sine wave signature

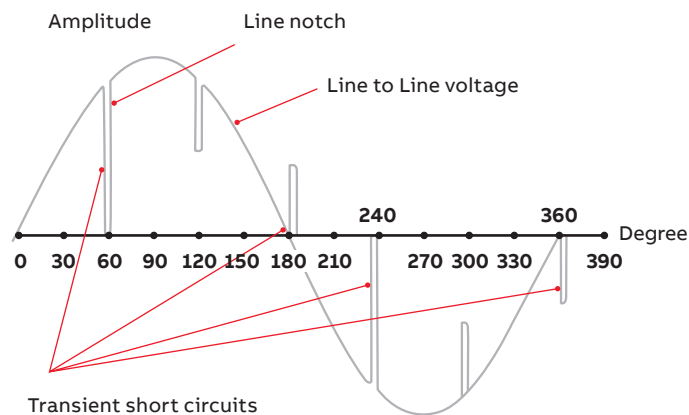

Information annex (cont.)

Structural Integrity

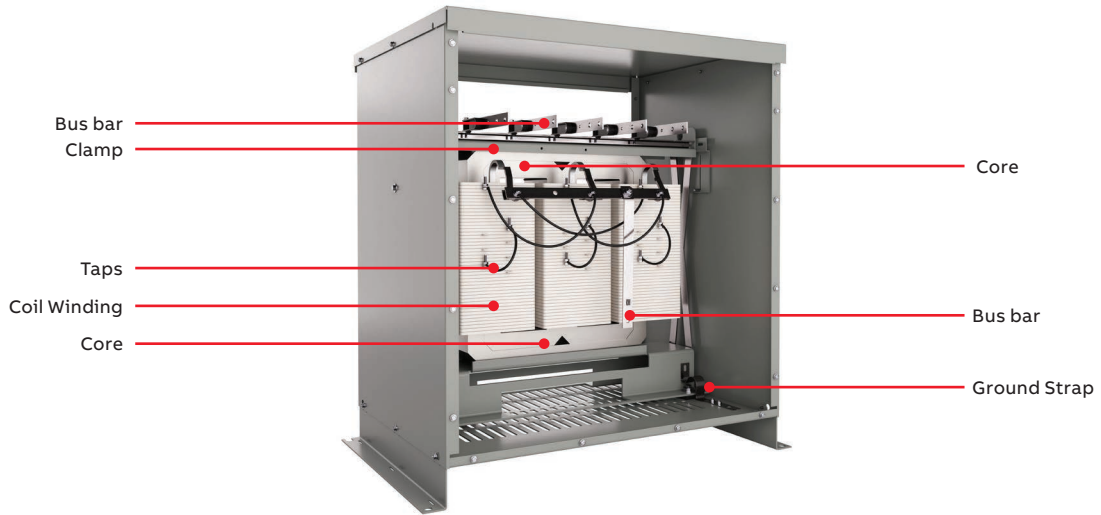

White paper: Reverse feeding low voltage dry type transformers

Abstract

Reverse feeding transformers has been a practice in the electrical industry for many years. While possible and to a point, successful, reverse feeding a transformer presents technical issues that should not be overlooked. Several key transformer attributes are compromised when reverse-feeding a dry type transformer. Therefore, the most reliable installation is to install a transformer designed for its application. Nevertheless, the quick restoration of interrupted power may lead toward the installation of a transformer by reverse feeding. This paper presents some technical issues that must be considered with reverse feeding a low voltage dry type transformer.

Introduction

General purpose dry type transformers rated 600 volts and below are used for supplying appliance, lighting, and various linear and/or non-linear loads within an electrical distribution system. These transformers are used to convert the facility distribution voltage to the load's utilization voltage. Most general purpose transformers are used in stepdown applications. The most used polyphase transformer in the United States has a 480 volt three-phase delta primary and a 208/120 volt three-phase, four-wire, wye secondary. This is known as a Delta-Wye transformer. Step-up transformers are available, but because step-up applications are rare these transformers are not typically stocked. So, step-up transformers are mostly built-to-order and construction can take six weeks or longer.

When there is an immediate need for a non-stock step-up transformer, it has been a common practice to use an in-stock

step-down transformer and install it in reverse fashion (reverse feed). If permitted by local codes and allowed by the authority having jurisdiction, it is generally acceptable to reverse feed (or back-feed) a transformer. Considering the complexities of a reverse-feed transformer installation, the electrical contractor owns the complete installation.

Nevertheless, there are several issues that must be considered before reverse feeding a step-down transformer. This paper discusses a reverse-feed application and presents the technical challenges from reverse feeding a low voltage dry type transformer.

Structural integrity

As an electromagnetic machine, the transformer “machine” has no moving parts to transfer energy, this energy transfer is accomplished through electromagnetism using the magnetic flux that is inherent in the transformer core. The magnetic flux has a limit or saturation point of its flux density. When the flux density exceeds or “saturates”, the magnetic properties of the transformer core degrade exponentially causing excessive energy loss, higher core vibrations that presents greater stress on the insulation system which could cause premature failure, appreciable audible noise from those vibrations will be easily heard and the entire core & coil of the transformer will experience higher than designed operating temperatures. All these factors alone should be a concern as the expected transformer life of 20-30 years of operation could be dramatically reduced.

Voltage taps

A standard step-down transformer usually contains taps on the input (primary) side, placing the taps on the primary side is called out in the NEMA ST-20 (sec. 2.1) transformer

Information annex (cont.)

standard. Lowering the primary side taps will increase secondary voltage and raising the primary taps will lower the secondary voltage. When a transformer is reverse fed, the taps move to the output side and so their operation is reversed. For reverse fed applications, raising the taps will increase output voltage and lowering the taps will lower output voltage.

The primary purpose of these taps is to match the input rating of the transformer to the actual voltage applied to the primary terminals to provide the output (secondary) voltage that most closely matches the load requirement. The taps must be used with care since no-load or low-load conditions combined with variance in the utility service voltage can cause an over-excitation of the winding, resulting in higher than rated core loss and excitation current. This is generally not a serious concern unless the over-voltage exceeds 5%. For reverse feed applications, the taps are positioned at the output side and so cannot be used to correct for over-excitation.

There is a fine line with the voltage taps and reverse feeding which should arise a concern as misapplication could cause premature transformer failure or other adverse effects such as over-heating and excessive vibration that causes noise and excessive wear on the insulation system.

Compensated windings

Voltage drop across transformers increases with load. At no-load a transformer's primary: secondary voltage ratio may exactly match the winding turns ratio. At full-load the same transformer's secondary voltage could be 3- 4% less than the turns ratio would dictate. The transformer winding turns ratio can be compensated to correct for this phenomenon. Smaller (less than 3 kVA) transformers commonly have compensated windings. Winding turns ratios are compensated so that a 3-4% over-voltage exists at no-load, but nominal secondary voltage is available at full load. Some manufacturers build larger transformers (>10 kVA) with compensated windings, although this is not a common practice due to the extra costs involved in manufacturing such a transformer.

When transformers with compensated windings are reverse fed, the compensation is reversed. As a result, the transformer voltage drop will be 3- 4% at no-load and 6-8% at full load. The transformer's taps may be able to correct for this additional voltage drop, but extra caution is required to have a transformer installation that provides the correct voltages.

Inrush currents

Upon energization, transformers will draw a high inrush current for a brief period (typically 0.1 seconds or less). The inrush current can be on the order of eight to twelve times the

rated full load current of the transformer. For a specified input voltage and VA rating, the inrush current for a reverse fed step-down transformer will be greater than the inrush current for a transformer specifically designed and installed as a step-up transformer.

To illustrate, assume that a standard ABB 9T10A1004 step-down transformer will be used in a step-up application. This transformer is rated 75 kVA, 60 Hz, 480 volt three-phase delta primary and 208/120 volt three-phase, four-wire, wye secondary. This transformer also contains six (6) 2.5% voltage taps on the primary (480 volt) side, 2 taps above nominal and 4 taps below nominal. For reverse feeding application, the secondary is to be operated step-up (208 VAC input to 480 VAC output).

The installer may discover that the primary side overcurrent protection, having been properly selected and applied per Article 450 (Table 450.3) of the National Electrical Code, nevertheless operates (trips) when attempting to energize the reverse operated transformer.

This tripping phenomenon can occur because the low impedance winding (the 208Y/120 VAC winding) that was intended by design to be the secondary winding, now serves as the primary and the value of the magnetizing inrush current (Mag-I) is much greater than expected.

The Mag-I experienced when energizing transformers is like the inrush current associated with motor starting. The primary and secondary full load amps of the above referenced transformer are 90 amps @ 480 VAC and 208 amps @ 208 VAC. When connected as the intended design as a step-down transformer and energized at 480 VAC, the maximum peak inrush current is approximately 990 amps or 11 times the rated 90 amp primary winding full load current. But when connected in reverse and energized at 208 VAC, the maximum peak inrush current can reach 7700 amps or 37 times the rated 208 amp secondary winding full load current ($7700/208 \approx 37$). To accommodate this high inrush current without the nuisance tripping of the overcurrent protective device, the input (208 VAC side) overcurrent protective device must be sized at a higher value than the allowed National Electric Code Article 450. Clearly, in this case, a National Electric Code violation (adopted by most state electrical codes), would occur creating a potential fire hazard at best and safety concern at worst.

Grounding

When the secondary (wye) of a delta- wye transformer is energized instead of the primary (delta), then the wye side of the transformer is not a separately derived service according to the National Electric Code Article 250. As such, the neutral

Information annex (cont.)

should not be connected to building ground nor should it be bonded to the transformer enclosure. The delta side of the transformer becomes the output, which is the separately derived system. The output delta “B” phase should be tied to ground unless the facility distribution system utilizes a different grounding scheme. As with compensation taps, extra caution is required as a wrong installation could prove to become a safety hazard.

Corner grounding a delta transformer presents different overcurrent protection device challenges. The IEEE 3004.5 standard Sec. 5.4.2 (Fig 13) should be referenced along with the National Electric Code Art. 450 to understand the overcurrent protection challenges and requirements.

CONCLUSION

Standard step-down transformers may be reverse fed for step-up applications but there are several significant precautions that must be considered (not all inclusive):

Structural integrity – by reverse feeding the step down transformer, extra stresses will be applied to the transformer for which it was not designed to handle. Great care is needed to assure that these thermal and mechanical compromises are worth the reverse feed installation.

Voltage taps – the over-excitation with its extra core loss (lower efficiency rating) must be considered if a reverse feed application is required. Lower installed efficiency values could violate the US Federal Regulation 10 CFR 431 (DOE) or the CSA 802.2 (NRCAN) laws. The function of the taps becomes a greater challenge as the taps no longer match the primary voltage to the secondary, rather it does this voltage matching in reverse. (the nameplate does not provide guidance to this usage).

Higher inrush current – the higher inrush currents that will occur in reverse feeding, will likely violate the overcurrent protection device requirements of the National Electric Code Article 450. Proper overcurrent protection is a requirement in most municipalities, a properly sized overcurrent protective device will likely trip each time the transformer is energized.

Compensated windings - Transformers with compensated windings (most do not have compensated windings) will have output voltage 3-4% below nominal at no-load and 6-8% below nominal at full load. The transformer’s taps may be able to correct for this under-voltage condition, but extra caution is required to have a transformer installation that provides the correct voltages.

Grounding – an essential installation requirement. The reverse feed of a Delta-Wye transformer no longer allows the neutral of the Wye portion of the transformer to be used as a grounding means as a separately derived source. The separately derived source becomes the Delta side and extra caution needs to be considered when grounding a delta transformer to prevent imbalances and short circuit currents issues.

Local codes – always review applicable codes and standards along with consulting the local authority having jurisdiction (AHJ) before reverse feeding transformers.

Considering the explanation and for permanent installations, ABB recommends that transformers be specified and installed to match the installation requirements. However, in temporary installations to resolve immediate power issues, a step-down transformer can be successfully installed in reverse. The specifier, installer and inspector must understand the technical challenges and compromises presented, the potential code related issues, and the potential safety concerns of the installation. ABB manufactures step-up transformers and these are available from ABB as made-to-order items. Critical factors (but not all possible) to consider when specifying a low voltage dry type transformer are:

- Primary (supply) voltage and system (Delta or Wye) – most common is Delta 480 V.
- Secondary (Load) voltage and system (Wye or Delta) – most common is Wye 208/120
- Load profile – linear and/or non-linear loads (50% or more of non-linear loads, consider a K-Factor transformer)
- Amount of energy required for the loads – (kVA) – also known as the transformer’s capacity
- The acceptable temperature rise – 150 °C being the most common, lower temperatures are available
- The maximum ambient temperature – 40 °C being the most common, equatorial, or desert areas may require a higher ambient temperature, usually 50 °C.
- Coil Material – Copper or Aluminum
- Special Requirements, such as installation location, impedance, presence of harmonics, electrostatic shielding, lower audible noise required, special approvals, etc.

Reference materials

IEEE C57.96: IEEE Guide for Loading Dry Type Distribution and Power Transformers

NEMA ST-20: Dry Type Transformers for General Applications

IEEE C57.12.01: IEEE Standard for General Requirements for Dry Type Distribution and Power Transformers

IEEE C57.105: IEEE Guide for Application of Transformer Connections in Three-Phase Electrical Systems

NFPA 70 – National Electric Code

IEEE 3004.5: IEEE Recommended Practice for the Application of Low Voltage Circuit Breakers in Industrial and Commercial Power Systems

ABB Inc.

305 Gregson Drive
Cary, NC 27511

electrification.us.abb.com

GE is a trademark of GE.

Manufactured by ABB Inc. under license from GE.

We reserve the right to make technical changes or modify the contents of this document without prior notice. With regard to purchase orders, the agreed particulars shall prevail. ABB Inc. does not accept any responsibility whatsoever for potential errors or possible lack of information in this document.

We reserve all rights in this document and in the subject matter and illustrations contained therein. Any reproduction, disclosure to third parties or utilization of its contents – in whole or in parts – is forbidden without prior written consent of ABB Inc. © 2022 ABB. All rights reserved.